

MINOLTA

E INSTRUCTION MANUAL

MAXXUM[®]

3000i

Your new Minolta Maxxum 3000i camera is by far the world's easiest-to-use autofocus SLR camera ever. Minolta's "intelligent" automation assures unparalleled accuracy and ease of operation. You can take sharply focused, properly exposed pictures one after another and rely on your Maxxum 3000i to deliver outstanding results from one roll of film to the next.

Some of the Maxxum 3000i's most impressive features include:

- Intelligent autofocusing that responds at very low light levels and feature a wide focus area for faster, easier focusing of moving subjects.
- Intelligent exposure which uses dual-area metering system that is coupled to the auto-focus system.
- Intelligent flash to automatically activate a dedicated flash unit when flash is needed.
- Automatic film transport that makes film handling completely reliable.
- World's most compact, most lightweight AF-SLR.

The world's largest selection of autofocus system accessories is available for your Maxxum 3000i camera. Ultra-compact Maxxum Flash D-316i and D-314i are designed exclusively for the Maxxum 3000i camera. The entire system of Maxxum AF lenses can be used, including the compact AF 35-80mm and AF 80-200mm lenses. Data Back DB-3 permits imprinting of the date or time on your pictures.

We know you want to begin using your new camera right away. Before starting, please read through this manual to learn how your Minolta Maxxum 3000i operates.

TABLE OF CONTENTS

PREPARATION AND BASICS

Names of parts	2
Data panel	
Attaching the lens	6
Care of glass surfaces	
Attaching the neckstrap	8
Battery information	10
Loading the battery	
Checking the battery condition	
Cold weather operation	
Battery performance	
Automatic setting of the film speed	13
Loading film	13
OPERATING THE CAMERA	
Holding the camera	17
Viewfinder	18
Taking pictures	19
Automatic film rewind	21
Manual start of film rewind	
Using flash	23

FOCUS

Autofocus	24
Focus hold	
Manual Focus	25
Special situations	26

EXPOSURE MODES

Program mode	27
High-speed program mode	28

ADDITIONAL INFORMATION

Main switch	29
Audible signals	30
Self-timer operation	30

ACCESSORIES	32
------------------------------	----

TROUBLESHOOTING GUIDE	36
--	----

TECHNICAL DETAILS	38
------------------------------------	----

CARE AND STORAGE	41
-----------------------------------	----

Names of parts

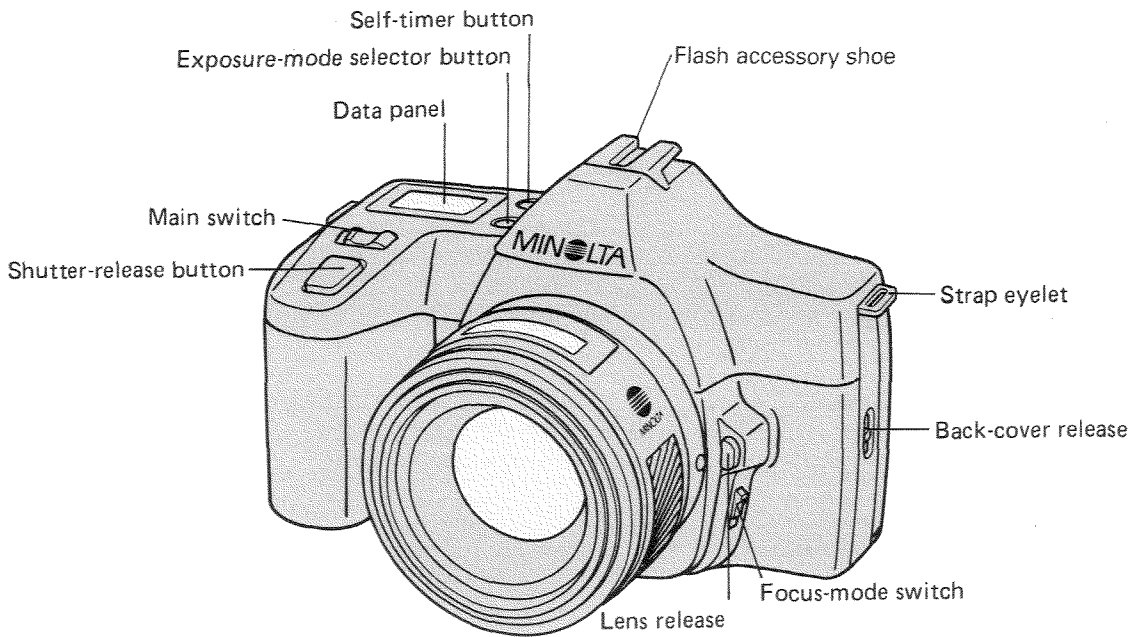

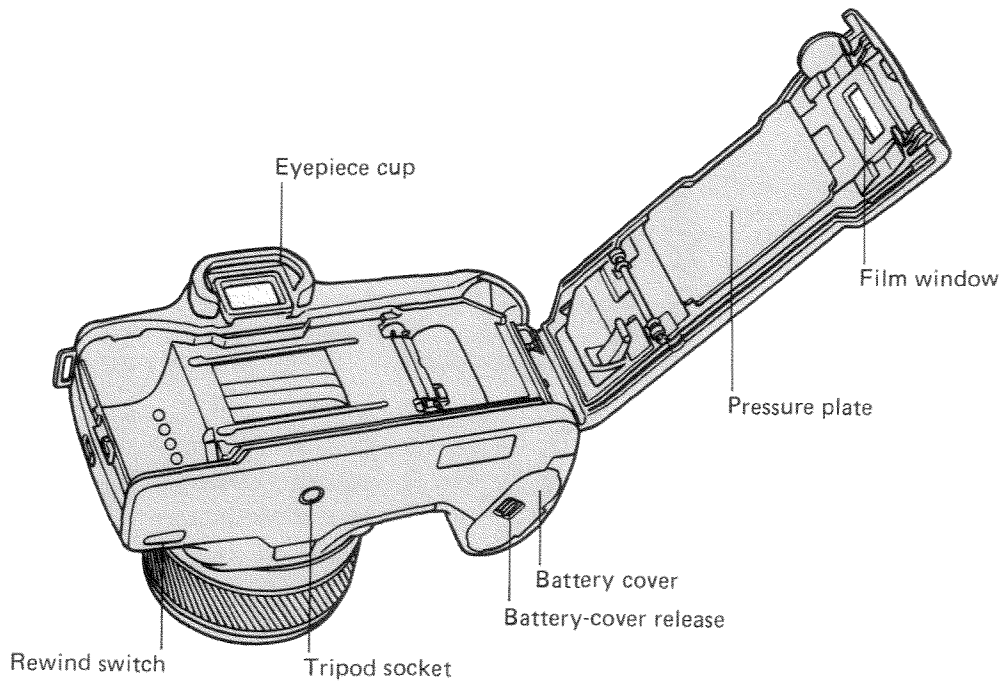

Data panel

- A. Program exposure mode
- B. High-speed program exposure mode
- C. Frame counter
- D. Film-transport signals
- E. Film-cartridge symbol
- F. Self-timer indicator
- G. Battery condition indicator

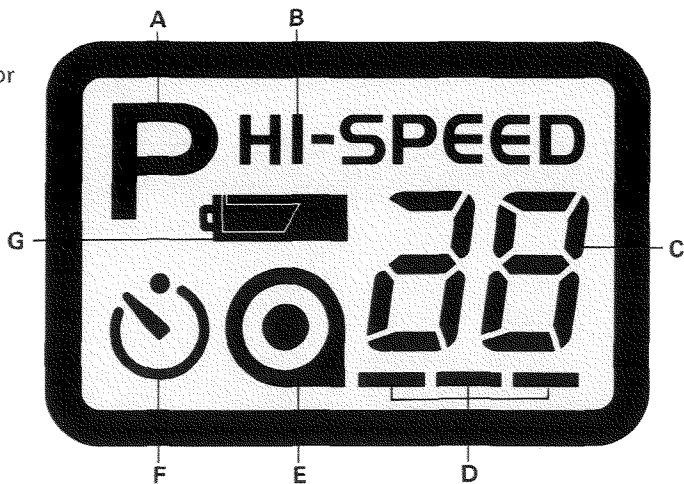

IMPORTANT INFORMATION

The Minolta Maxxum 3000i camera is designed to offer innovative functions and performance through the combination of the camera body, Maxxum AF lenses, Minolta Maxxum Flash units, and other accessories distributed by Minolta. We thus caution users that the attachment or use of incompatible lenses, flashes, and accessories may result in unsatisfactory performance or damage to the Minolta Maxxum 3000i camera. To obtain optimum performance throughout the life of your Minolta Maxxum 3000i camera, we recommend that you use only lenses, flashes, and other accessories distributed or licensed by Minolta for the Maxxum 3000i camera.

PREPARATION AND BASICS

Attaching the lens

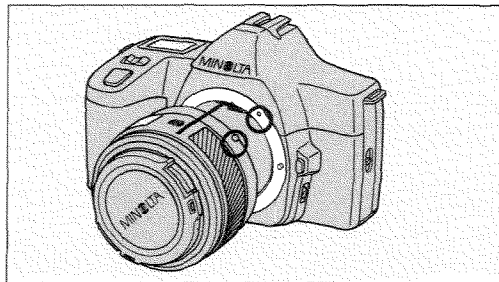
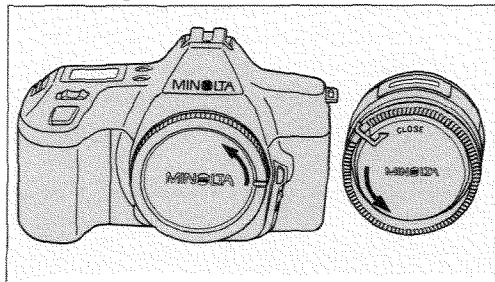

To attach

1. Remove body cap and rear lens cap as shown.

- When attaching or removing lenses, never touch anything inside the camera, especially the lens contacts or mirror.
- To protect the lens contacts and elements, attach the lens caps whenever the lens is not in use.

2. Align red bead on lens barrel with red dot on camera's lens mount.

Insert lens bayonet into mount and turn lens clockwise until it locks in place with a click.

If lens is not attached properly, frame counter shows "--" when camera is switched on.

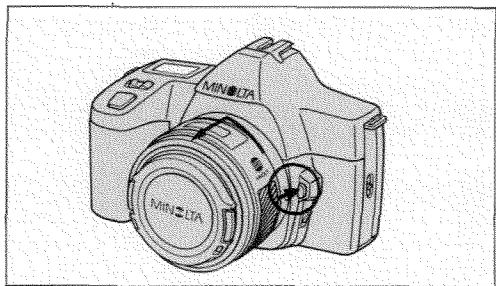

To remove:

1. While pressing lens release, turn lens counterclockwise as far as it will go, then lift lens out of mount.
2. Attach another lens or the body cap to prevent dust from entering the camera.

Care of glass surfaces

- Never touch lens elements or the camera's eyepiece with your fingers. If the lens becomes dirty, clean it gently with a lens brush. Only if necessary, moisten a sheet of lens tissue with one drop of lens-cleaning fluid. Then, starting at the center and using a circular motion, lightly wipe the surface of the lens.
- Never lift the mirror or touch its surface, as this may impair its alignment. Dust specks on the mirror's surface will not affect exposure or picture quality. If they are annoying, the camera can be cleaned at an authorized Minolta service facility.

Attaching the neckstrap and eyepiece cap

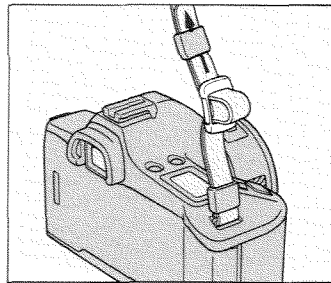
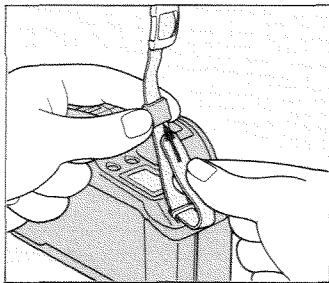
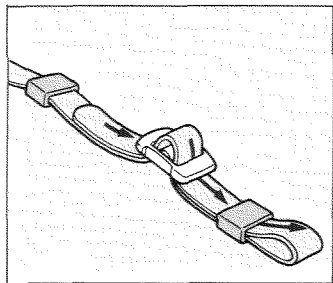

A neckstrap is supplied with your Minolta Maxxum 3000i. Attach it to the camera as shown above.

An eyepiece cap is also supplied and can be slipped onto the neckstrap to keep it handy for use.

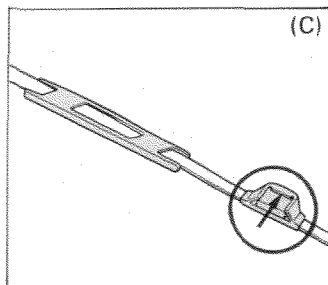
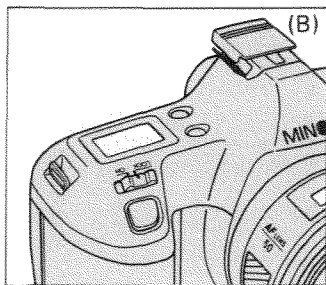
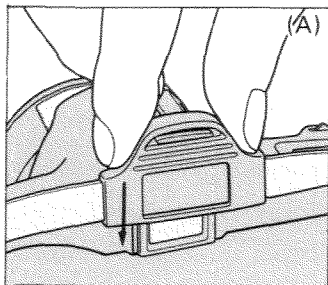

The eyepiece cap slides over the eyepiece frame to prevent stray light from entering the eyepiece and affecting exposure. It should be used whenever the eyepiece is not shielded by your head, as when using the self-timer. To attach the eyepiece cap, first remove the eyepiece cup, then slip the cap over the frame (A).

An accessory shoe cap is supplied that slips into the accessory shoe to protect the contacts from dust and grime (B). When using a flash unit, slip the accessory shoe cap into the eyepiece cap (C).

Battery information

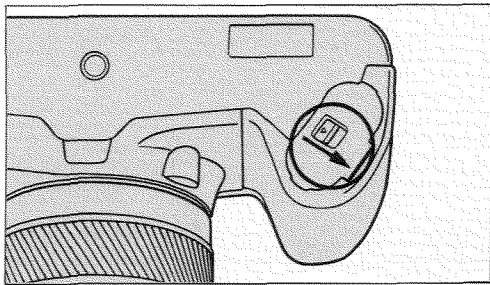

The Minolta Maxxum 3000i uses a 6-volt 2CR5 lithium battery. This battery supplies power for all camera operations, including film winding, autofocus, and exposure control.

Power for Maxxum Flashes D-316i and D-314i is supplied by the camera's battery. Refer to the flash's instruction manual for more information.

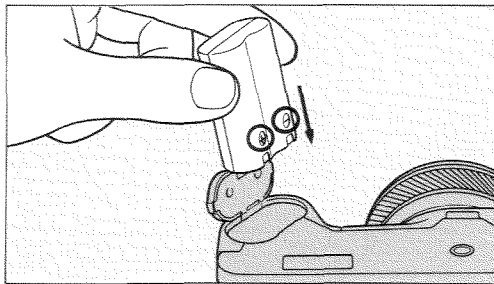

Loading the battery

1. With main switch at LOCK position, slide battery-cover release in direction shown to open battery cover.
 2. Insert the 2CR5 lithium battery as shown above, then snap battery cover closed.
- Before inserting, wipe battery terminals with a dry cloth to ensure proper contact.

Checking the battery condition

Each time you slide the main switch from LOCK to ON position, the camera automatically checks the battery's condition:

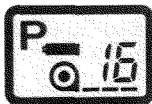

Full-battery symbol appears for five seconds when power is sufficient.



Low-battery symbol appears for five seconds: Power is sufficient but getting low—**keep a fresh battery handy.**



Low-battery symbol blinks: Camera can be operated, but **the battery should be changed.**



Only low-battery symbol blinks or no indications appear and shutter cannot be released: Power is too low for normal operation—**change battery immediately.**

NOTES

- Do not mishandle the battery. Do not attempt to disassemble, recharge, or short out the battery, or subject it to high temperatures or fire. The battery may explode or cause burns.
- Read and follow all warnings and instructions supplied by the battery manufacturer.
- Keep battery away from young children.

Cold-weather operation

Lithium batteries provide excellent performance in cold weather. However, if you plan to shoot many rolls of film outdoors at temperatures at or below 32°F (0°C), we recommend that you carry the camera inside your coat to keep it warm when not taking pictures. You may also wish to carry a spare battery in a warm pocket, so that you can change the battery, if necessary. Do not discard a cold battery. After it warms up, its capacity will be restored.

Battery Performance

The 6-volt 2CR5 lithium battery should provide sufficient power for shooting up to 55 rolls of 24-exposure film without flash, and up to 25 rolls of 24-exposure film using flash D-314i on 50% of the exposures.

These figures are based on Minolta's standard test method using a fresh battery at 20°C (68°F). Actual battery performance will depend on how you use your camera.

Automatic setting of the film speed

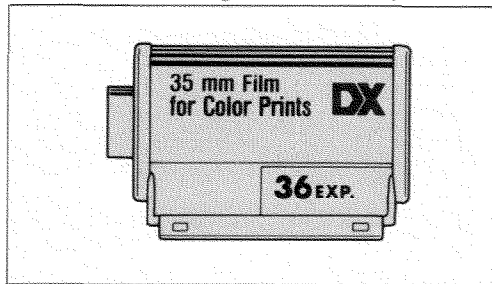

We recommend using ISO 32-3200 DX-coded films since the camera sets the film speed automatically for these films. If you use other types of film, beyond this ISO range or not DX-coded, the film speed will be set at ISO 100.

- DX-coded films have "DX" printed on their film cartridges and film boxes.

Loading film

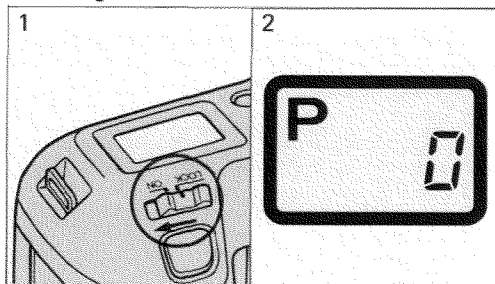

1. Set the main switch to ON position.
2. Check the frame counter. When the frame counter shows "0", it is safe to open the back cover.
 - If the frame counter shows any number besides "0", film is loaded in the camera.
 - You can also check the film window to see if film is loaded.
 - Refer to page 22 for instructions to rewind a partially exposed roll of film.

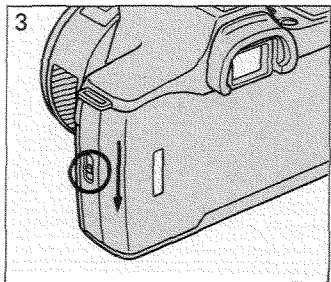

3. Open the back cover by sliding the release downward.

- Always load film in subdued light or at least shaded from direct sunlight.
- When you load film for the first time, remove and discard the protective plastic cover which is attached to the pressure plate.

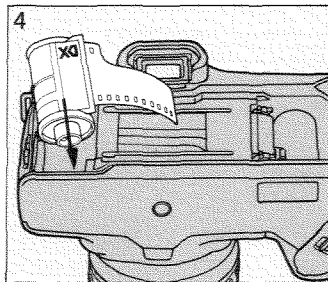

4. Place film cartridge into film chamber as shown here.

5. Extend tip of film past orange mark. Make sure the holes in the lower edge of the film engage the teeth on the sprocket.

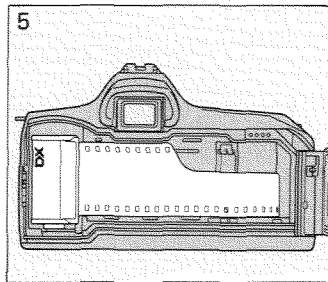

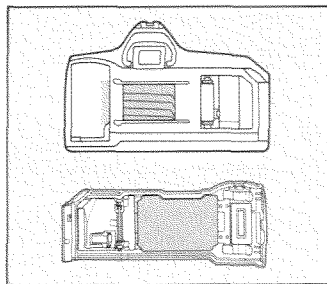
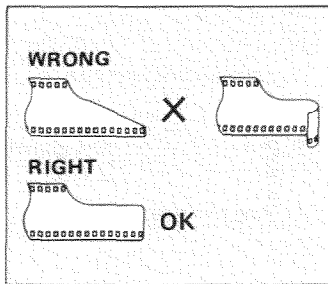
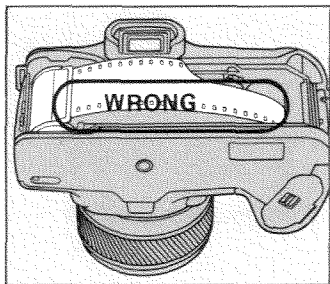

● If the film extends too far or does not lie flat, gently push the excess back into the cartridge.

● Make sure tip of the film is shaped correctly. Otherwise, the film may not wind properly.

● Do not touch any parts or areas shown in blue.

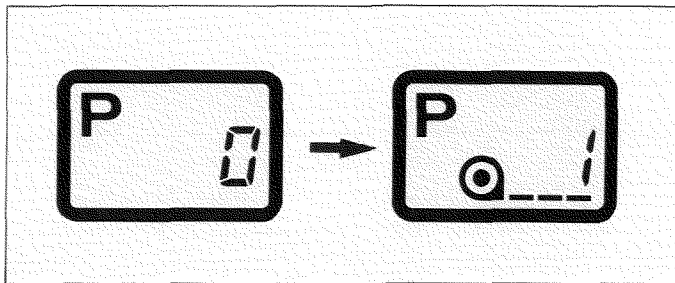
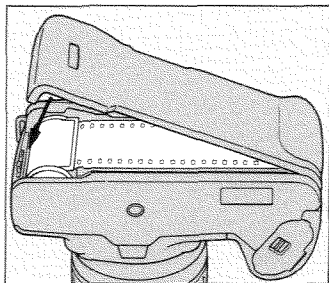

6. Close the back cover and make sure it snaps shut. The camera will automatically wind the film to the first frame. **When the film is loaded correctly, "⊙_ _!" will appear in the data panel.**

● The film speed for DX-coded films is set automatically. You are now ready to start taking pictures.

● If film is not loaded correctly, " _ _!" in data panel will blink and camera will beep for one second. The shutter cannot be released and the camera will beep each time the shutter-release button is pressed. Repeat steps 3 through 6.

OPERATING THE CAMERA

Holding the camera

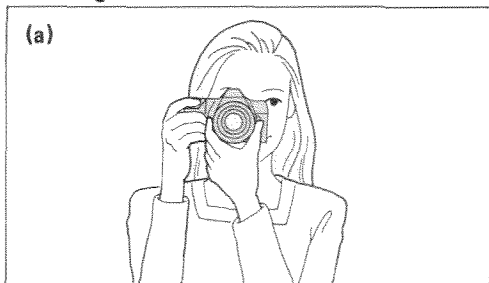

To obtain sharp, blur-free photos, hold the camera as still as possible and steady it against your face or body. Press the shutter-release button gently with a slow, steady squeeze—never a quick jab.

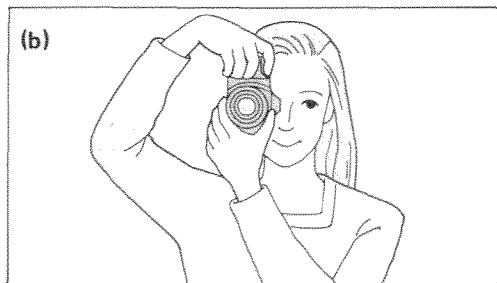

Two recommended ways of holding the camera are shown here. If you grasp the camera firmly with your right hand on its handgrip, you can shift the camera back and forth for horizontal (a) and vertical (b) pictures without removing your hands from the controls. When using autofocus, make sure you do not touch the lens' focusing ring.

Viewfinder

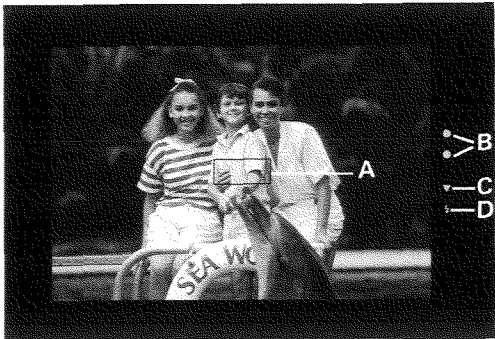

A. **Focus frame:** Center this area on your subject.

B. **Focus signals:** Green (lower) signal glows when subject is in focus. Red (upper) signal blinks when focus cannot be confirmed by camera. If using autofocus, switch to manual-focus mode.

C. **Use-flash signal.** Blinks when flash should be used, such as in low light or with backlit subjects. Continues to blink while flash unit is charging. At this time, shutter cannot be released until flash is fully charged.

D. **Flash-ready signal:** Blinks slowly when flash is charged and ready to fire. Blinks rapidly to indicate flash exposure was sufficient.

Taking pictures

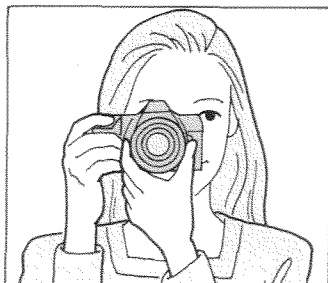
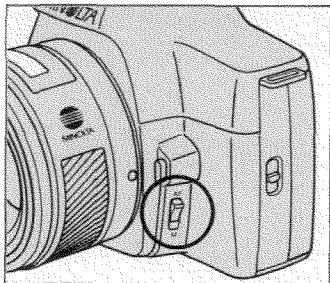
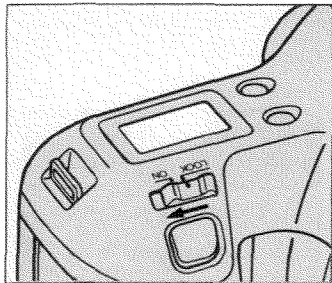

1. Slide the main switch to ON position.
2. Set the focus-mode switch to AF position for autofocusing.
 - M position is used for manual focusing.
3. Hold the camera firmly with your right hand on its handgrip and support the lens with your left hand.

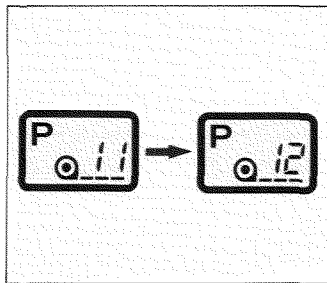
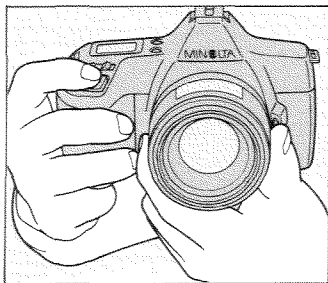
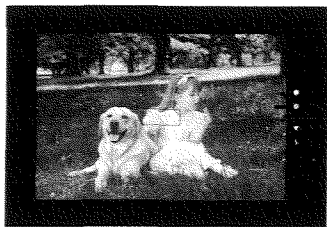

4. While looking through the eyepiece, center the focus frame on your subject and, after checking for the green focus signal, gently press the shutter-release button all the way down.

- The camera will focus automatically. The green focus signal in the viewfinder will glow when the subject is in focus. Also, the camera will beep as the subject comes into focus.
- If the red focus signal blinks, focus cannot be confirmed by the camera and the shutter will not release. Focus the lens manually.

- If the use-flash signal (▼) in the viewfinder blinks, a flash should be used; the shutter can be released without flash, but exposure may not be correct.
- After taking the picture film is automatically advanced to the next frame and the frame counter increases by one.
- When taking pictures of a moving subject, press the shutter release button all the way down without checking for the green focus signal.

Automatic film rewind

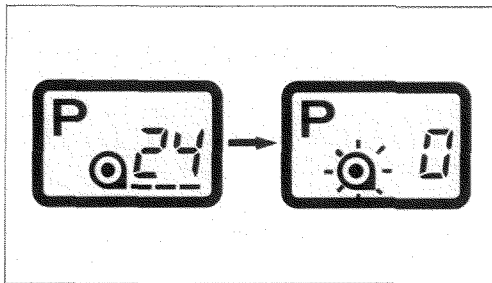

After the last frame is exposed, the camera will automatically start rewinding the film. With a fresh battery loaded in the camera, it normally takes just 12 seconds to rewind a 24-exposure film and 16 seconds for a 36-exposure film.

When the film is completely rewound the rewind motor switches off automatically. At this time the film-cartridge symbol in the data panel blinks to indicate that the film may be removed, and 0 appears in the frame counter. While rewind is in progress, the frame number of the last exposure remains in the frame counter.

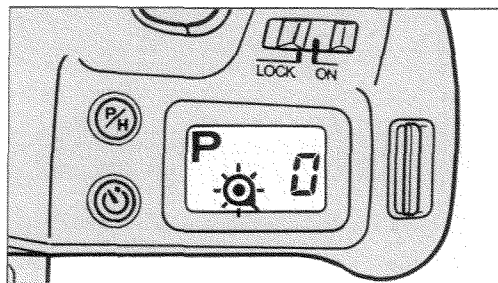

If the film cartridge is left in the camera after the film is rewound, the shutter cannot be released and the camera will beep each time the shutter-release button is pressed.

- To stop film rewind before the film is completely rewound, slide the main switch to LOCK. To restart automatic film rewind, slide the main switch to ON.

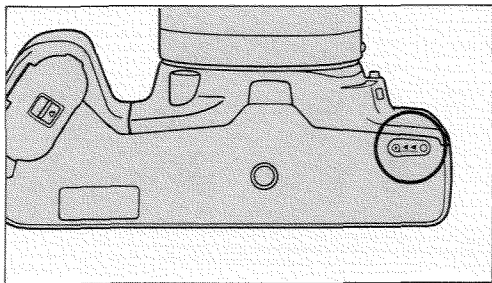

Manual start of film rewind

You can manually start film rewind when you want to remove a roll of film before the last frame is exposed. Before manually starting film rewind, check that battery power is sufficient (see page 11). Then press the rewind button (on the bottom of the camera) with a ball-point pen or similar object to start the rewind motor.

- If you accidentally open the camera's back cover before the film is rewound, close it immediately. Press the rewind button to finish rewinding the film. Light falling on the film will ruin many of the pictures, but your quick action may save a few .
- Before starting rewind you should check the battery condition indicator in the data panel. If the blinking low-battery symbol is displayed, the battery should be replaced. Although you may be able to take pictures following a blinking low-battery indication, the camera's rewind function may not be operable in this case.