

MINOLTA

MAXXUM[®]
DYNAX[™]

9xi

E INSTRUCTION MANUAL

The “philosophy of camera design” that guided to the development of the Dynax/Maxxum 9xi can be described in three words: Performance, Control, Reliability. This manual is devoted to helping you learn how to control the 9xi and its many features:

- Expert AF with high-speed response, Multi-/Omni-Dimensional Predictive focus control, and 4.5 frames/sec.-sequence shooting with continuous and predictive control
- A top shutter speed of 1/12000 sec. and x-sync speed of 1/300 sec.
- Expert AE's multiple metering modes, Expert Program Selection, and Creative Program Control
- The Quick button, which provides bracketing, multiple exposures, or an immediate, temporary change to one of three pre-selected camera functions
- The metering index

in addition to a host of others. The options which these controls and features provide you, however, are only a small part of *Expert Control*.

As you use the 9xi, you will also discover that *Expert Performance* and *Expert Reliability* play a large part in complementing your own photographic expertise and in raising your skills to a higher level. In short, this means that when you use the 9xi, you can rest assured that you hold in your hands a hardworking, dependable craftsman's tool that will help you deliver superior results for a long time to come.

Performance, Control, Reliability — the 9xi.

IMPORTANT INFORMATION

The Minolta 9xi was designed to work specifically with lenses, flash units, and other accessories manufactured and distributed by Minolta. We therefore caution users of this camera that the attachment and/or use of incompatible products with the 9xi may result in unsatisfactory performance or damage to the camera or its accessories. To obtain optimum performance throughout the life of your 9xi, we recommend that you use only those lenses, flashes and other accessories distributed by Minolta specifically for use with this camera.

STATEMENT OF FCC COMPLIANCE

This device complies with Part 15 of the FCC Rules. Operation is subject to the following two conditions: (1) This device may not cause harmful interference, and (2) *this device must accept any interference received, including interference that may cause undesired operation.* Changes or modifications not approved by the party responsible for compliance could void the user's authority to operate the equipment. This equipment has been tested and found to comply with the limits for a Class B digital device, pursuant to Part 15 of the FCC Rules. These limits are designed to provide reasonable protection against harmful interference in a residential installation. This equipment generates, uses and can radiate radio frequency energy and, if not installed and used in accordance with the instructions, may cause harmful interference to radio communications. However, there is no guarantee that interference will not occur in a particular installation. If this equipment does cause harmful interference to radio or television reception, which can be determined by turning the equipment off and on, the user is encouraged to try to correct the interference by one or more of the following measures:

Reorient or relocated the receiving antenna.

Increase the separation between the equipment and receiver.

Connect the equipment into an outlet on a circuit different from that to which the receiver is connected. Consult the dealer or an experienced radio/TV technician for help.

STATEMENT OF DOC COMPLIANCE

This digital apparatus does not exceed the Class B limits for radio noise emission from digital apparatus as set out in the Radio Interference Regulations of the Canadian Department of Communications.

TABLE OF CONTENTS

Names of Parts	4
PREPARATION	
Standard Accessories	11
Lens	12
Battery	14
FOCUS	
Autofocus	24
AF Illuminator	25
Focus Frame	26
Focus Signals	27
METERING	
Metering Modes	32
Metering Mode Selection	34
EXPOSURE	
Exposure Mode Selection	39
P: Programmed Autoexposure	40
PA/PS: Creative Program Control	41
A: Aperture-Priority Autoexposure	42
S: Shutter-Priority Autoexposure	43
FLASH	
Viewfinder Flash Signals	53
P-mode Flash and Manual Fill-Flash	53
A, S, and M-mode Flash	54
ADDITIONAL FEATURES	
Program-Reset Button	57
Self-Timer	58
Film Drive	59
Quick Button	60
<i>br</i> : Exposure bracketing	61
<i>F_b</i> : Flash bracketing	61
<i>ME</i> : Multiple exposure	62
<i>dr</i> : Drive-mode selection	63
APPENDIX	
Accessory Information	73

Care and Storage	8
<hr/>	
Diopter Adjustment	17
Film	18
Eye-start	22
<hr/>	
Focus Lock	28
Special Focusing Situations	29
Manual Focus	30
Local Focus Area Selection	31
<hr/>	
Using Spot Metering	35
Metering Index	37
<hr/>	
M: Manual Exposure	44
Manual Shift	45
Bulb	46
Exposure Compensation	48
AE Lock	50
Exposure Warnings	51
<hr/>	
Miscellaneous Flash Notes	54
Slow-Shutter Sync	55
<hr/>	
<i>SF</i> : Spot-metering selection	64
<i>RF</i> : Autofocus-area selection	64
Control Dials	65
Depth-of-Field Preview	66
Panorama Indicators	67
Focal-Length Display	68
Release Priority	69
Wide-View Mode	70
<hr/>	
Technical Details	77

NAMES OF PARTS

Body

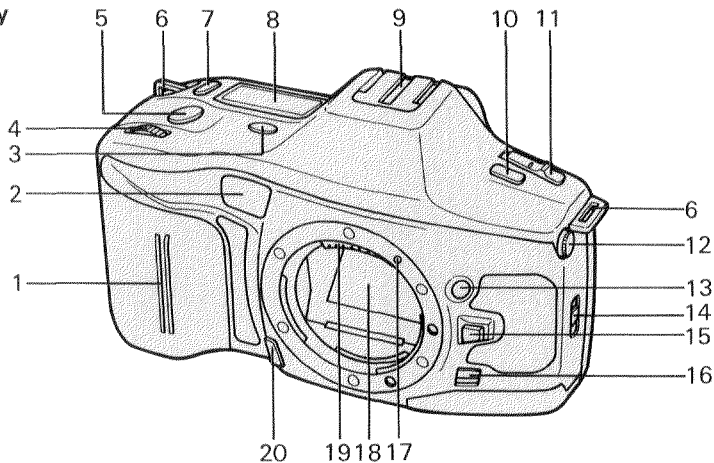

- | | |
|--|--|
| 1. Grip sensor (22) | 11. Main switch |
| 2. AF illuminator/self-timer light (25/58) | 12. PC terminal (54) |
| 3. Wide-view mode button (70) | 13. Flash-control button (53) |
| 4. Front control dial (65) | 14. Back-cover release (18) |
| 5. Shutter-release button | 15. Lens release (13) |
| 6. Strap eyelet (11) | 16. Focus-mode switch (30) |
| 7. Card on/off button | 17. Mounting index |
| 8. Body data panel (6) | 18. Mirror* |
| 9. Accessory shoe | 19. Lens contacts* |
| 10. Program-reset button (57) | 20. Depth-of-field preview button (66) |

* Do not touch

For information on specific parts, refer to the page numbers shown in parentheses.

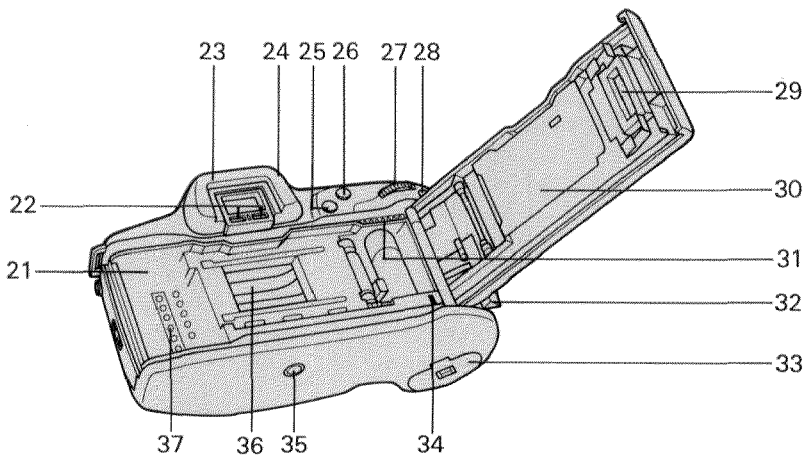

- | | |
|----------------------------------|------------------------------|
| 21. Film chamber | 29. Film window |
| 22. Eyepiece sensor (22) | 30. Pressure plate* |
| 23. Eyepiece cup | 31. Accessory-back contacts* |
| 24. Diopter-adjustment dial (17) | 32. Card door |
| 25. AE-lock button (50) | 33. Battery cover (14) |
| 26. Quick button (60) | 34. Film-leader index (18) |
| 27. Rear control dial (65) | 35. Tripod socket |
| 28. Function button (65) | 36. Shutter* |
| | 37. DX contacts* |

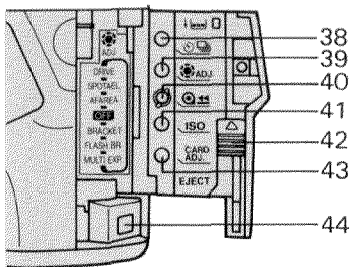

Inside Card Door

- | |
|--|
| 38. Self-timer/drive-mode button (58/59) |
| 39. Quick-adjust button (60) |
| 40. Rewind button (21) |
| 41. ISO button (20) |
| 42. Card-eject slide |
| 43. Card-adjust button |
| 44. Remote-control terminal (47) |

Body Data Panel

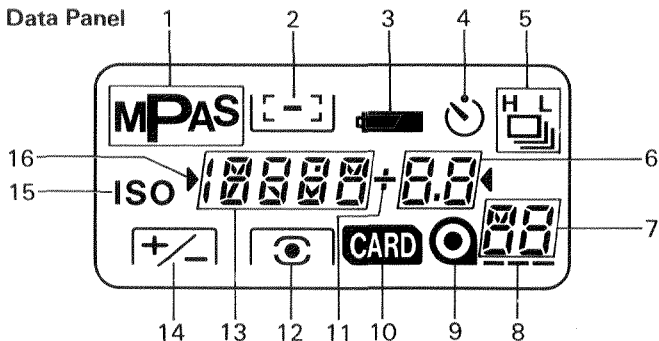

1. Exposure-mode indicators (39)
2. Wide/local-focus indicator (31)
3. Battery-condition indicator (15)
4. Self-timer indicator (58)
5. Drive-mode indicator (59)
6. Aperture/Exposure-compensation/Card-setting display
7. Frame counter/Quick-setting display
8. Film-transport signal (19)
9. Film-cartridge mark (19, 21)
10. Card indicator
11. Exposure-compensation indicator (48)
12. Metering-mode indicator (32)
13. Shutter-speed/Film-speed/Card-name/Local-AF-area display
14. Exposure-compensation reminder (48)
15. Film-speed mark (20)
16. Selectable setting pointers

Viewfinder

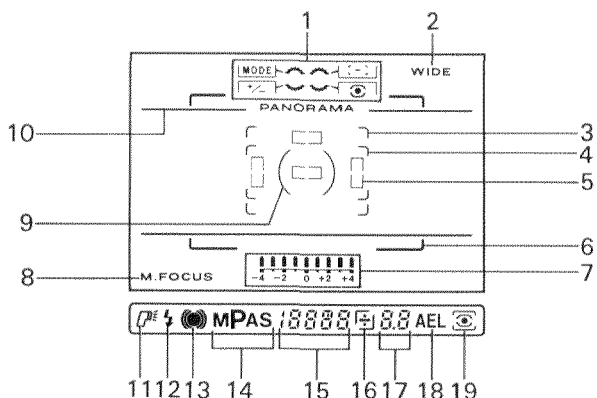

Viewfinder Screen

1. Dial-function indicators (65)
2. Wide-view indicator (70)
3. Horizontal wide-focus frame (26)
4. Vertical wide-focus frame (26)
5. Local-focus areas (31)
6. Film-frame indicators (70) (wide-view mode)
7. Metering index (37)
8. Manual-focus indicator (30)
9. Spot-metering area (35)
10. Panorama indicator (67)

Viewfinder Data Panel

11. Flash-on indicator (53)
12. Flash-ready indicator (53)
13. Focus signals (27)
14. Exposure-mode indicators (39)
15. Shutter-speed/Film-speed display
16. Exposure-compensation indicator (48)
17. Aperture/Exposure-compensation display
18. AE-lock indicator (50)
19. Metering-mode indicator (32)

For information on specific displays and indicators, refer to the page numbers in parentheses.

CARE AND STORAGE

- Always keep your camera in its case with the lens capped when not in use, or with a body cap on when a lens is not attached.
- No part of the camera should be forced at any time.
- 72-exposure cartridges and Polaroid 35mm instant film cannot be used.
- Never subject your camera to shock, high heat, humidity, water, or harmful chemicals. Be particularly careful not to leave it in the glove compartment or other places in motor vehicles where it may be subjected to high temperatures.
- Never lubricate any part of the camera body or lens.
- Never touch the shutter curtains, mirror, or the interior of the body or clean them with compressed air. Doing so may impair their alignment and movement.
- External camera surfaces and the lens barrel—but not glass surfaces—can be cleaned by wiping with a dry or silicon-treated cloth. Never use organic solvents to clean the camera.
- Never touch the lens or eyepiece surfaces with your fingers. Whisk away loose matter with a blower brush. To remove stubborn spots, use a sheet of photographic lens tissue. If necessary, tissue may be moistened with one drop of lens-cleaning fluid; never place fluid directly on glass surfaces.
- We recommend that you have your camera cleaned once a year at an authorized MINOLTA Service Facility.
- If you plan to store your camera for an extended period of time, rewind and remove the film, then remove the battery. Place the camera in a cool, dry place away from dust or chemicals, preferably in an airtight container with a drying agent such as silica gel. Also, it is recommended that you periodically release the camera's shutter to maintain proper working condition.

- This camera is not waterproof, dustproof or sand-proof. If you use this camera near water or at the beach, water-, dust-, or sand-damage may occur. Protect it at all time from moisture or splashes, especially saltwater spray, and be extremely careful to keep sand from both the interior and exterior of the camera and its accessories. If it comes in contact with water, wipe it with a clean, dry cloth and bring it to an authorized MINOLTA Service Facility. If it comes in contact with sand or if sand enters the camera, gently blow away loose particles —**wiping may scratch the camera**— and bring it to an authorized MINOLTA Service Facility.
- If the camera is subjected to a sudden change in temperature, as when transferring it from a cold environment into a heated building, condensation may form inside. To prevent condensation, place the camera in a sealed plastic bag before transferring it from a cold place to a warm environment, and wait for it to come to room temperature before taking it out of the bag.
- After prolonged storage, and especially before taking pictures at an important event, carefully check the operation of the camera and lens.
- The operating range for camera's data panel is from -20 to 50°C (-4 to 122°F). At temperatures outside this range, response time and contrast will change, making the display difficult to read. At very high temperatures, a display may temporarily darken. If this occurs, the display should return when the camera is restored to operating range conditions.
- This camera contains no user-serviceable parts. Do not attempt to disassemble or repair the camera yourself.
- This camera's circuitry may switch off, even when a battery with sufficient power is installed. To resume operation, remove the battery and install it again.
- If *HELP* appears in the body data panel, remove the battery, then re-install it. If it appears again after you release the shutter, take the camera to a MINOLTA Service Facility.

PREPARATIONS

STANDARD ACCESSORIES

Neckstrap

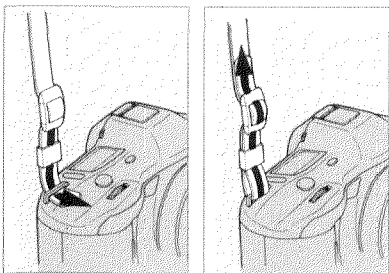

A neckstrap is supplied with your camera. Attach it as shown.

Eyepiece and Accessory Shoe Cap

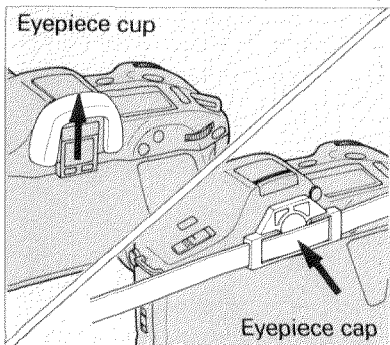

An eyepiece cap is attached to the strap. Remove the eyepiece cup and attach it to the viewfinder eyepiece when you use the self-timer or make long exposures.

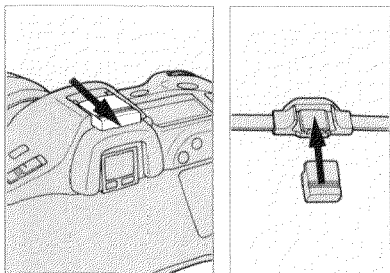

The camera also comes with an accessory-shoe cap which protects the accessory-shoe contacts. When you are using a flash or other accessory, slide the accessory-shoe cap into the eyepiece cap for safekeeping.

LENS

Attaching

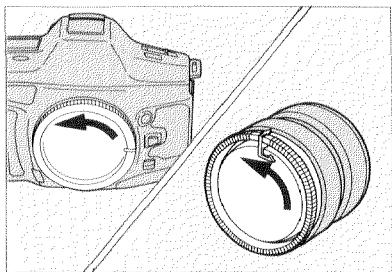

1. Remove the body cap and rear lens cap as shown.

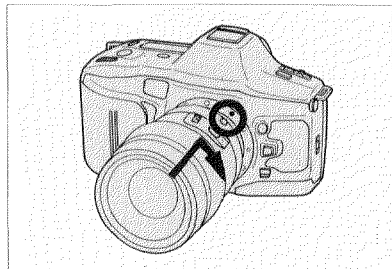

2. Align the red bead on the lens barrel with the red dot on the camera's lens mount. Gently insert the lens into the mount and turn the lens clockwise until it locks in place with a click.

Be careful...

- Do not force the lens onto the body if it does not turn smoothly.
- Never touch anything inside the camera, especially the lens contacts and mirror.



- If no lens is attached to the camera or if the lens is not attached properly, "--" will appear in the body data panel and viewfinder data panels when Eye-Start activates the camera.

Removing

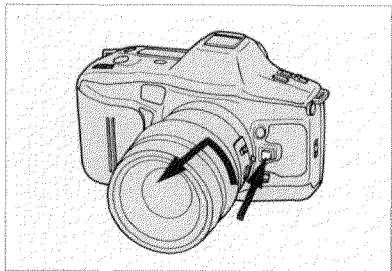

1. While pressing the lens release, turn the lens counterclockwise until it stops. Lift the lens out of the mount.

2. Immediately attach the rear cap to the lens and the body cap or another lens to the camera. This will protect the camera interior, lens contacts, and lens elements.

Care of Glass Surfaces

- Never touch any lens surfaces (including the eyepiece) with your fingers. If a lens surface becomes dirty, first gently clean it with a lens brush. Then, if necessary, moisten a sheet of lens tissue with one drop of lens-cleaning fluid and, starting from the center of the lens, wipe the glass with a circular motion.
- Never lift the mirror or touch its surface, because this may impair the mirror's alignment or scratch its face. Dust on the mirror will not adversely affect meter readings or picture quality. If it is distracting, have the camera cleaned at an authorized Minolta service facility.

BATTERY

The camera uses a 6-volt 2CR5 lithium battery which supplies power for all camera operations. If you are using an xi-Series lens, the camera battery also supplies power to the lens' zoom motor.

Installation

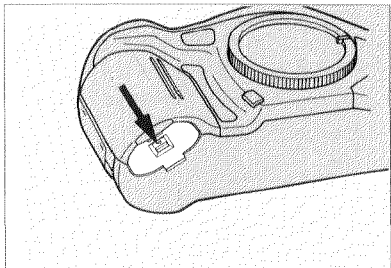

1. Set the main switch to LOCK and slide the battery-cover release in the direction indicated to open the battery cover.

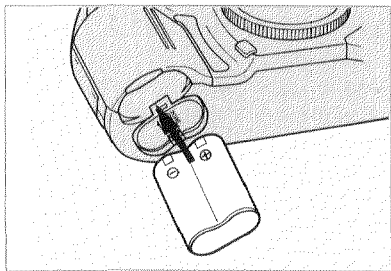

2. Insert the battery according to the marks on the inside of the chamber cover.

3. Snap the cover closed.





● Sometimes it helps ensure good contact to wipe the battery terminals with a clean, dry cloth.

CAUTION

- Read and follow all warnings and instructions supplied by the battery manufacturer.
- Do not attempt to disassemble, recharge, or short-circuit the battery. Do not subject it to high temperatures or fire. The battery may explode and cause severe burns.
- Keep batteries away from small children.

Battery-condition Indicators

Whenever you move the main switch from **LOCK** to **ON**, one of the following indicators will appear in the body data panel.

Indicator	Meaning
	1. Full-battery symbol appears for 4 sec. after you turn camera on. Power is sufficient.
	2. Low-battery symbol appears for 4 sec. after you turn camera on—power is sufficient, but getting low. Keep a fresh battery handy.
	3. Low-battery symbol blinks while it appears with other operating indicators at any time during use—camera can be operated, but power is extremely low. We recommend that you change the battery soon.
	4. Blinking low-battery symbol and “ <i>bAtt</i> ” appears, or no display appears at all and shutter locks—power is insufficient for operation. Replace the battery or check that the battery is inserted correctly.

- Indicators 1-3 will not appear while a dedicated, accessory flash is charging.
- Indicator 4 will appear even while the main switch is set to **LOCK**.

Battery Performance

The 6-volt 2CR5 lithium battery should provide sufficient power for shooting up to 50 rolls of 24-exposure film. These figures are based on Minolta's standard test method using a fresh battery at 68°F (20°C). Actual battery performance will depend on how you use the camera. Also, if you install a new battery that has been in prolonged storage, battery performance may vary.

Cold-Weather Operation

Lithium batteries provide excellent performance in cold weather. However, if you plan to shoot many rolls of film in temperatures near or below 32°F (0°C), we recommend that you carry the camera inside your coat while you are not shooting to keep it warm. You may also want to carry several spare batteries in your pocket so that you can change the camera battery if necessary. Do not discard a cold battery. After it warms up, it will regain some of its charge.

DIOPTER ADJUSTMENT

Use the diopter-adjustment dial to adjust the viewfinder eyepiece between -2.5 and $+0.5$ power. For additional correction, attach an Eyepiece Corrector 1000.

To adjust:

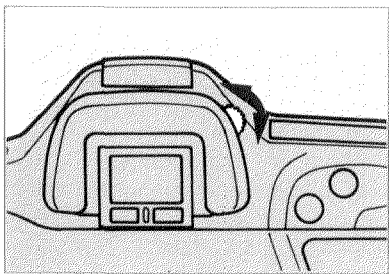

1. Focus on a subject, preferably one that is not moving.
2. Turn the diopter-adjustment dial until the subject's image in the viewfinder screen appears sharpest.

FILM

Loading Film

Before you load film, always check the body data panel. If the film cartridge is displayed, do not open the back cover. See page 21 for instructions on rewinding a partially exposed roll of film.

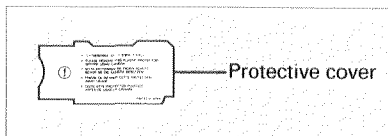

- Before you load film for the first time, remove and discard the protective cover in the film gate.

- Always load film in subdued or shaded light to limit the chances of fogging your film.

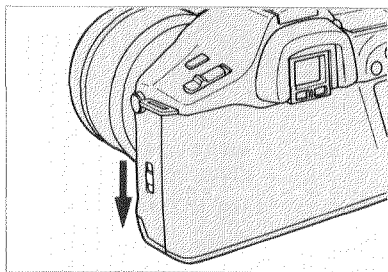

1. Open the back cover by sliding the back-cover release downward.

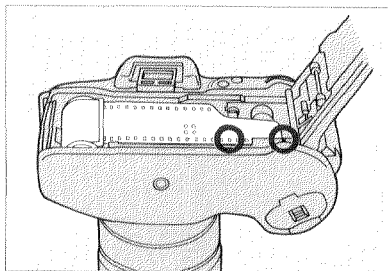

2. Place the film cartridge into the film chamber and extend the leader between the guide rails to the film-leader index. Make sure the sprocket holes in the film's lower edge are engaged by the camera's sprocket teeth.

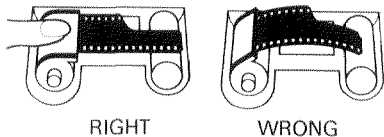

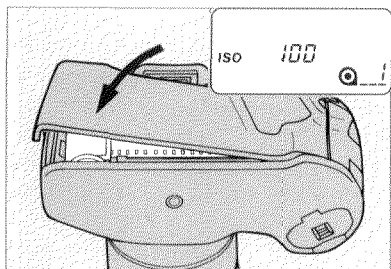

3. Close the back cover and move the main switch to **ON**. The camera will automatically advance the film to the first frame and **1** will appear in the film counter.

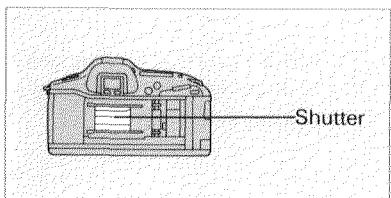

• **NEVER TOUCH THE SHUTTER CURTAIN WITH YOUR FINGERS OR WITH THE FILM TIP.** Its precision design makes it extremely sensitive to pressure.



• If the film is loaded incorrectly, **0** will blink in the frame counter and the shutter will remain locked. Open the back cover and repeat steps 2 and 3.

• Make sure the film leader is shaped correctly, otherwise the film may not advance properly. Trim a torn or bent film tip so that it looks like the correct one pictured at left.

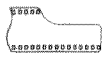

RIGHT



WRONG

• If the film tip extends beyond the red mark, gently push the excess film back into the cartridge.

• If you move the main switch to ON before you load film, do not touch the grip sensor during the above procedures.

Automatic Film Speed Setting



If you use DX-coded film, the camera will automatically set the correct film speed. The film speed setting will be displayed in the body data panel for 4 sec. after you load the film. To display the film speed to which the camera is set at any time, press the ISO button in the card door—the film speed will appear in the body data panel.

Manual Film Speed Setting

If you are using a non-DX-coded film or if you want to override the camera's automatic setting, you must manually set the film speed. The camera will initially set non-DX-coded film to the ISO of the previous roll.

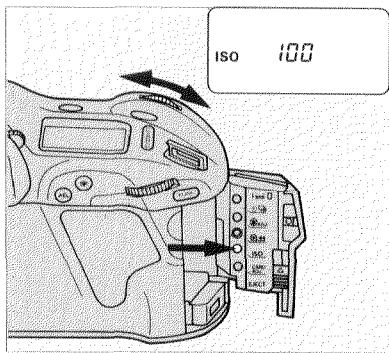

1. Load the film, open the card door and press the ISO button.
2. Turn the front control dial until the desired film speed setting appears in the body data panel.
3. Press the ISO button again to enter your selection and return to operating mode, or wait 4 sec. and the setting will be entered automatically.

- Each click of the dials will change the film speed setting by 1/3-stop between ISO 6 and 6400.
- For flash exposures, Minolta recommends that you use film between ISO 25 and 1000.

Automatic Rewind



After you have exposed the last frame, the camera will automatically rewind the film. With a fresh battery, it takes about 6 seconds to rewind a 36-exposure roll, or 5 seconds for a 24-exposure roll. When the film has been completely rewound, the motor will stop and the film-cartridge symbol in the body data panel will blink to indicate that it is safe to open the back cover.

Manual/Silent Rewind

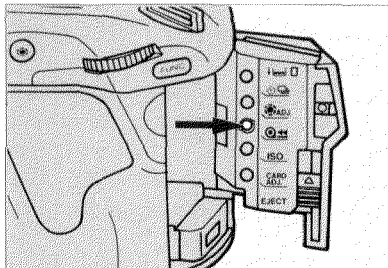

If you manually activate the camera's rewind motor, it will rewind the film silently. To begin film rewind manually, open the card door and press the rewind button. It will take approximately 10 seconds to rewind a 36-exposure roll or 8 seconds to rewind a 24-exposure roll.

- When the motor stops and the cartridge mark in the body data panel blinks, it is safe to open the back cover.
- If the motor stops before the film is completely rewound, insert a fresh battery. Do not open the back until the film cartridge mark blinks in the body data panel.

EYE-START

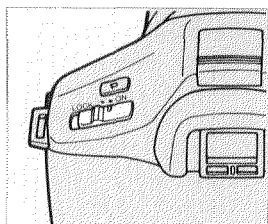

Main switch

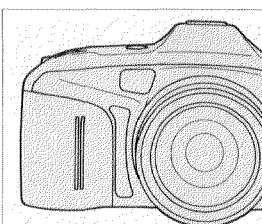

Grip sensor

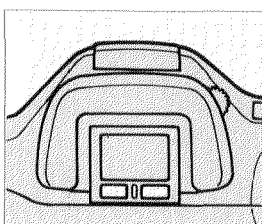

Eyepiece sensor

The Eye-start System automatically activates all of the 9xi's main systems as soon as you bring the camera to your eye. When you move the camera's main switch to **ON**, the body data panel and the grip sensor activate. Touching the grip sensor then activates an infrared emitter/detector located beneath the eyepiece. When the eyepiece sensor detects an object near the viewfinder, autofocus and autoexposure immediately activate so that the camera is already operating by the time you frame your main subject.

- If Eye-start does not function, you can activate the camera by pressing the shutter release partway down.
- When the eyepiece sensor no longer detects an object near the viewfinder, autofocus and autoexposure will automatically switch off.
- If you break contact with the grip sensor while you are looking through the viewfinder, autofocus and autoexposure will switch off four seconds later.
- If you are wearing sunglasses which absorb infrared light, Eye-start may not function.

FOCUS

AUTOFOCUS

When you look through the viewfinder and place your subject in the focus frame, the autofocus system automatically:

- Adjusts the focus frame for vertical or horizontal camera orientation.
- Determines which AF sensor is detecting the main subject.
- Activates continuous AF and maintains focus on moving subjects.
- Calculates where a moving subject will be at the time the shutter opens and sets focus to this point while the mirror swings up.

The 9xi also has focus-priority shutter release which prevents the shutter from releasing until the subject is in focus. This ensures a high percentage of sharp images when you are photographing a moving subject with continuous film advance. Release priority mode is also available. In it, continuous autofocus and predictive focus control will continue to function, but sharp focus is not required for the shutter to release. See page 69 for details.

AF ILLUMINATOR

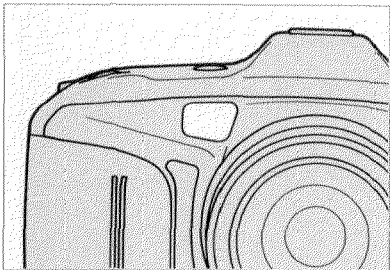

The 9xi's AF system operates in light levels as low as -1 EV (at ISO 100). In low light or when the contrast of your main subject is too low to be read by the autofocus sensors, the AF illuminator will automatically activate. It projects a pattern of lines onto your subject which the AF sensors can then detect.

- Be careful not to obstruct the AF illuminator while you are holding the camera.
- The range of the AF illuminator is 0.7 - 9m.
- The AF illuminator will not work if the focal length of the lens you are using is 300mm or longer (excluding AF Zoom/AF Zoom xi 100-300 and AF Zoom 75-300) or if you are using the 3X-1X Macro Zoom.

FOCUS FRAME

Fig. 1

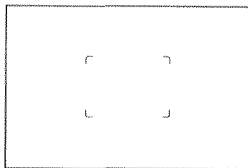

Fig. 2

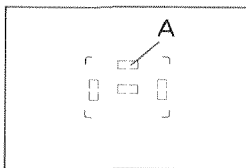
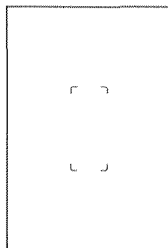

Fig. 3



The 9xi's ultra-wide focus area (fig. 1) provides you with a great deal of flexibility in composing your photographs and makes it easy to follow and maintain focus on fast-moving subjects. When you photograph, place your main subject somewhere in this frame and, when the green focus indicator lights to confirm that focus has been achieved (see Focus Signals, p.27), press the shutter-release button completely down to take the picture.

The ultra-wide focus area contains four autofocus sensors (fig. 2). When the camera's Expert AF system is activated, it will first determine which of the sensors is reading the main subject. When you press the shutter-release button partway down, if the subject is stationary focus will lock.

Sensor A in figure 2 will be used to focus on your subject's eyes when you take portraits with the camera held horizontally. When you turn the camera to take vertical pictures, this sensor will be switched off and the brackets which outline the focus frame will change to show the new frame (fig. 3).

You can also manually select any one of the AF sensors either full-time (Local Focus Area Selection, p.31) or temporarily (Quick Button p.60).

FOCUS SIGNALS

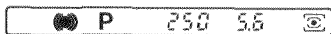

When the camera is activated, either by Eye-start or by pressing the shutter-release button partway down, the AF system begins evaluating the scene to determine the location of your subject within the frame. One of the following focus signals will appear in the viewfinder data panel:

	Continuous AF; focus is confirmed
	Stationary subject; focus is locked*
	Focus cannot be confirmed

* This only appears after you press and hold the shutter-release button partway down.

- None of the above indicators will appear while the lens is focusing.
- In autofocus mode, if focus cannot be confirmed, the shutter will lock unless you select release priority (p.69).

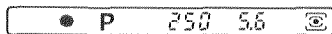
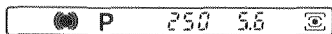

FOCUS LOCK

If, as a result of the composition or framing you have chosen, a stationary subject falls outside the focus area, first lock focus on it then recompose the scene as desired.



1. Place your subject in the center of the focus area.

2. Press the shutter-release button partway down.

3. Wait for the focus signal to change from  to  in the viewfinder data panel, recompose the image, and take the picture.

• Focus will remain locked if, after the shutter releases, you only let the shutter-release button partway-up and take another picture.

- With an xi-Series lens, you can also lock focus by pulling the lens control ring toward the camera or pressing the lens function button.
- When the camera is set to honeycomb-pattern metering, exposure and focus will be locked at the same time.
- When the metering mode is set to center-weighted average or spot, the exposure will not be locked with autofocus. You must use the AE lock button separately.

SPECIAL FOCUSING SITUATIONS

The camera's autofocus system will produce sharply focused pictures in almost any situation. In the cases described below, however, it may be difficult or impossible for the camera to correctly focus on your subject—you may have to use focus lock (p.28) or manual focus (p.30).

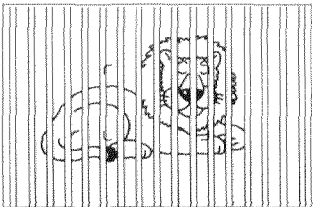

If two subjects at different distances overlap within the focusing frame.

- Photographing through windows should not be a problem unless they are very dirty or a window frame or other object passes through the focus frame.

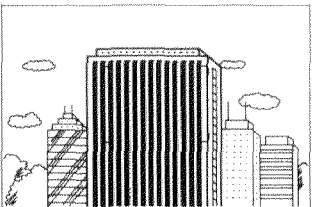

If a subject composed of alternating light and dark lines completely fills the focusing frame.

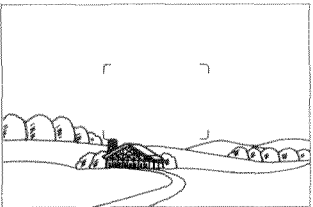

On very bright, very dark, or low-contrast subjects.

MANUAL FOCUS

To manually focus the lens:

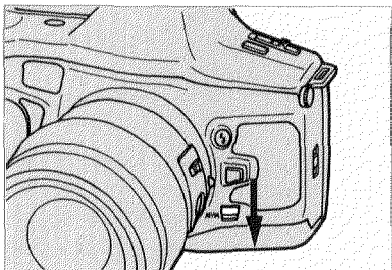

1. Slide the focus-mode switch down to set the camera to manual focus mode—**M. FOCUS** will appear in the viewfinder.

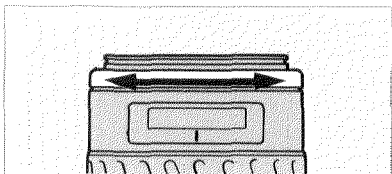

2. If you are using an AF-series lens, turn the focusing ring until the subject appears sharp. With an xi-Series lens or AF power zoom lens, pull and turn the control ring. For more information, refer to the lens manual.

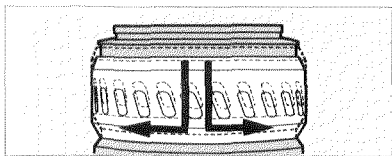

- Whenever any of the four AF sensors (three, if you are holding the camera vertically) detects a focused image, the green focus-lock signal will light.
- In manual focus mode, the shutter will release even if the subject is not in focus.
- To return to autofocus mode, slide the focus-mode switch down or press the program re-set button (p.57).

LOCAL FOCUS AREA SELECTION

If you want to use a specific AF sensor, you can manually override the selection sequence and use only one of the four sensors.

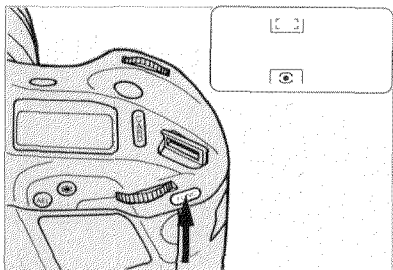

1. Press the function button twice.
●  will appear in the viewfinder.

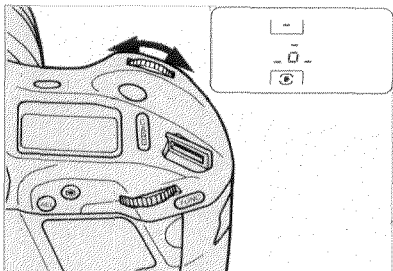

2. Turn the front control dial until the AF sensor you want appears in the viewfinder screen or body data panel.

3. Press the shutter-release button partway down to enter the area you have chosen and return to normal operating mode.

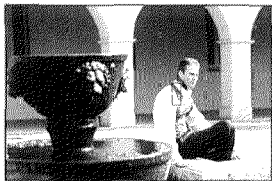

- Autofocus will not function while you are selecting a local AF area.
- You can also set the Quick button to make a temporary, pre-programmed change in the AF sensor the camera is using (see Quick Button, p.60).

METERING

METERING MODES

The 9xi has three metering modes: 14-segment honeycomb-pattern metering (☉), center-weighted average metering (◐), and spot metering (•). The camera's metering cell is divided into 13 honeycomb-pattern segments plus a background segment. These are used both singly and in various combinations to provide the necessary metering pattern and weighting.

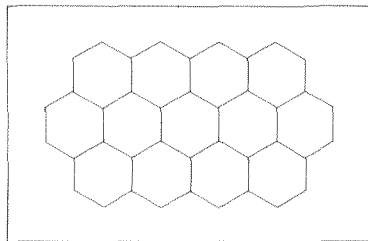

14-segment honeycomb
pattern metering

Fourteen-Segment Honeycomb-Pattern metering is the camera's standard metering mode and will be set whenever you press the program re-set button (p.57). This mode uses information from the autofocus system to set the metering pattern based on the position of the main subject in the frame. The camera then evaluates each of the honeycomb segments separately to determine the degree of spotlighting or backlighting present in your scene and selects the shutter speed and aperture accordingly.

In center-weighted average mode, the exposure is based on an average of the readings made by each of the honeycomb segments, with emphasis placed on the center of the image. Take care when photographing backlit, spotlit, or off-center subjects as the meter may include non-subject areas of your scene in the exposure calculation. To correct or prevent this, use exposure compensation (p.48) or AE lock (p.50).

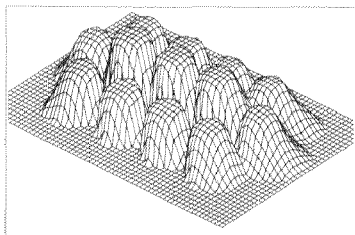

center-weighted
average metering

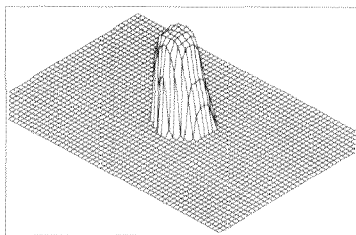

spot metering

Spot metering uses only the center segment of the honeycomb pattern to read the brightness of the subject inside the viewfinder's spot-metering area. Use this mode when you want to measure only a specific part of your scene or subject (see Using Spot Metering, p.35).

METERING MODE SELECTION

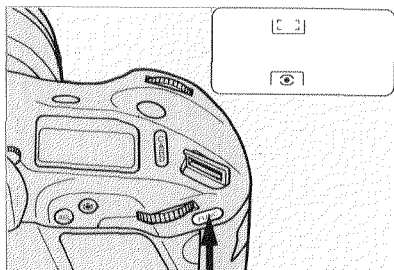

1. Press the function button twice.
 -  will appear in the viewfinder screen.

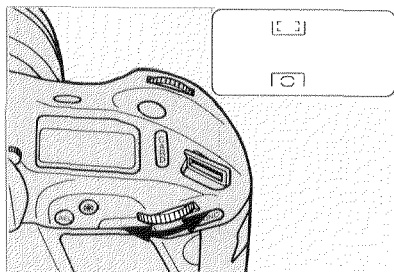

2. Turn the rear control dial to select the metering mode you want.
3. Press the shutter-release button partway down to enter your selection.

- 14-segment honeycomb-pattern metering
- Center-weighted average metering
- Spot metering

USING SPOT METERING

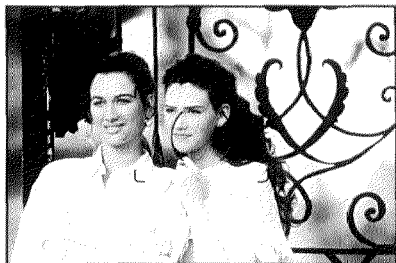

1. Center the spot-metering area in the viewfinder over the area of your scene or subject that you want to meter.

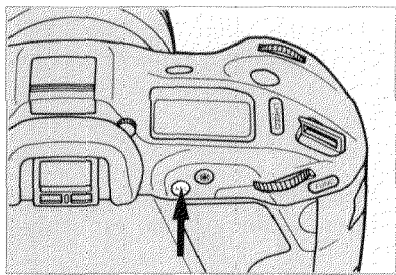

2. Press and hold the AE lock button.

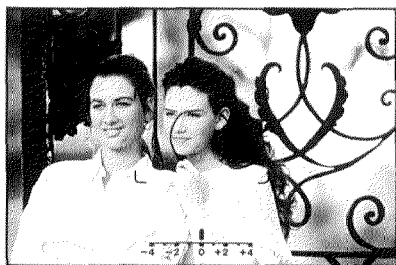

• The metering index will appear in the viewfinder.



— NEXT PAGE —

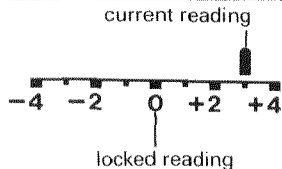

3. Recompose the scene as desired.

- The pointer on the metering index will indicate the difference between the locked exposure and the exposure required by the subject currently inside the spot area (See p.37). You can use this to make a quick comparison of highlight and shadow areas.

4. Press the shutter-release button all the way down to take the picture.

- In manual exposure (**M**) mode, the metering index will always appear and will display the difference between your exposure settings and those suggested by the camera's meter.

METERING INDEX

The table below summarizes the four situations in which the metering index will appear.

When the Index Appears		0 Position on Index	Pointer
P / A / S	14-Segment Honeycomb-Pattern metering is selected and the function button is pressed once (p.49)	Exposure calculated by center-weighted average metering	Current exposure settings*
	Center-weighted average metering is selected and exposure compensation is being added (p.49)	Un-biased center-weighted average reading	Amount of compensation
	In spot mode and the AE lock button is pressed and held (p.35)	Locked spot reading	Difference in exposure required by area currently inside the spot circle
In manual exposure mode (p.45)		Exposure calculated by camera using current metering mode	Difference in exposure provided by manual camera settings

*This will include any exposure compensation you have set manually in addition to the adjustment made by honeycomb-pattern metering for backlit, spotlight, or off-center subjects.

+1.5 EV



● When two pointers appear, the indicated value is between them.

● The pointer will blink if the indicated value is greater than +4 EV or less than -4 EV.

EXPOSURE